

# CT 7000

7000 GALLONS/31822 LITRES WATER TANK

DIAMETER	4150 MM
INLET HEIGHT	2750 MM
APEX HEIGHT	2980 MM



## Features

- Premium quality, UV protected and designed to withstand harsh Australian weather.
- Manufactured from 100% food grade polyethylene (No BPA).
- Fully self supporting roof and extra ribs for superior strength.
- Tapered walls and one-piece construction.
- Free delivery 600kms from Dalby branch.

PEOPLE REQUIRED ONSITE TO ASSIST WITH DELIVERY ③	3 + 1 DRIVER
WEIGHT	625 KG
TRUCK & TRAILER ACCESS REQUIRED FOR DELIVERY	

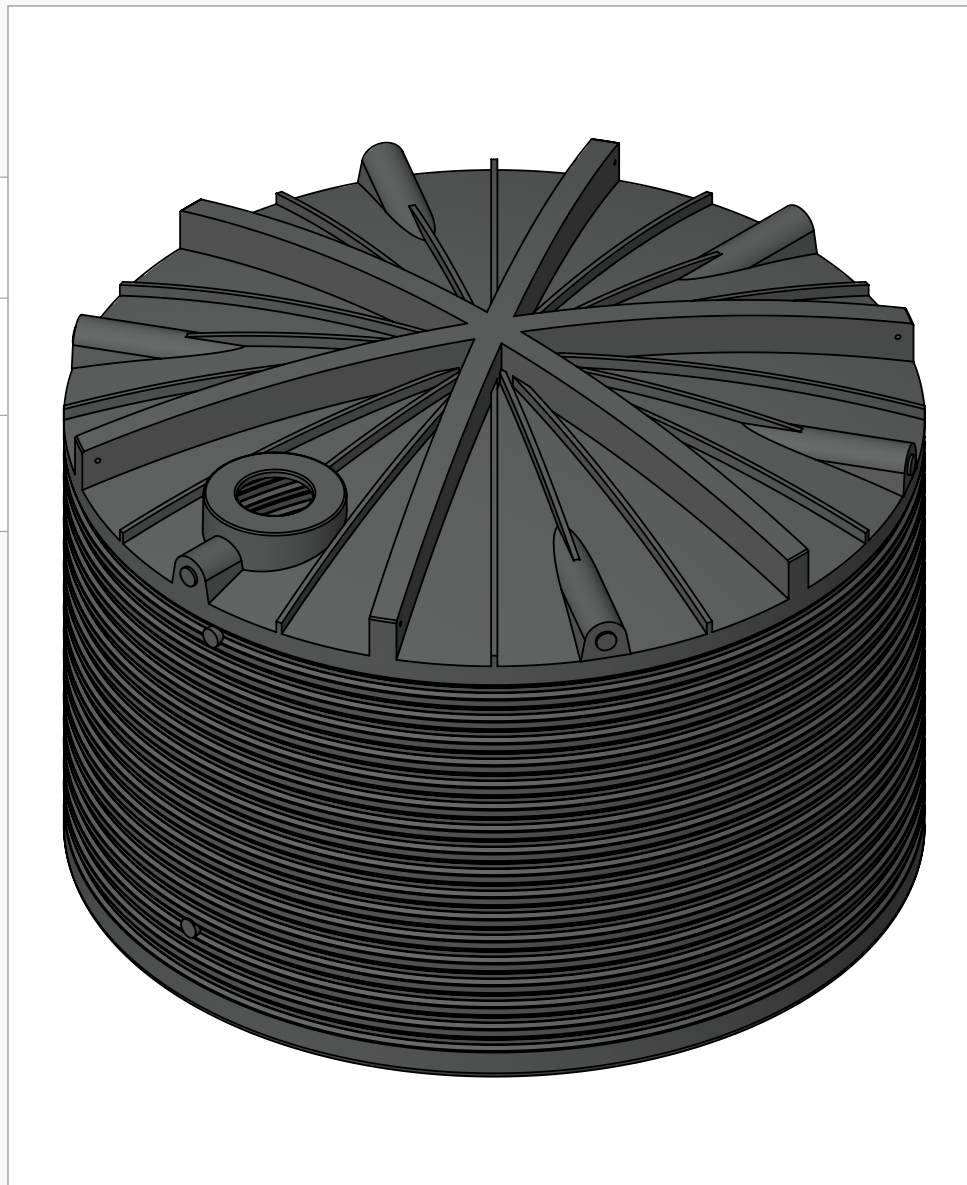

## Free Inclusions ①

(Brass outlet fitted prior to delivery, remaining fittings fitted onsite upon delivery)

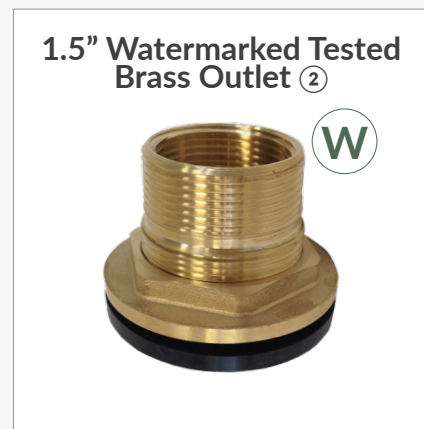
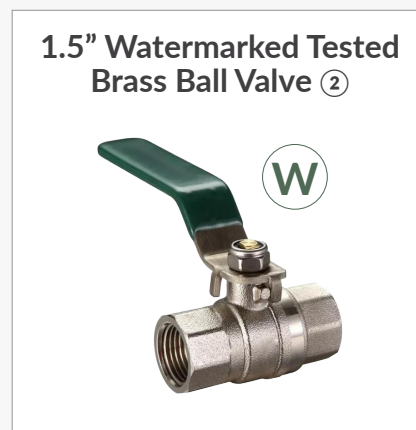

AVAILABLE IN ALL 32 COLOURS

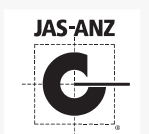

AS/NZS 4766:2006 Polyethylene Storage Tanks for Water and Chemicals Certification # 300/1



① Additional watermarked tested brass fittings or poly fittings are available on request (additional charges may apply).  
 ② Watermarked tested brass fittings available in 1", 1.5" & 2", poly welded fittings also available (additional charges may apply).  
 ③ Delivery & Installation guide available, enquire with our sales team for a copy.  
 ④ Warranty Conditions available on our website. \*Conditions apply.

Sizes shown are approximate sizes. Capacities listed are approximate maximum volumes. Prices quoted include GST. Specifications are subject to change. Product Certification applies to selected range.



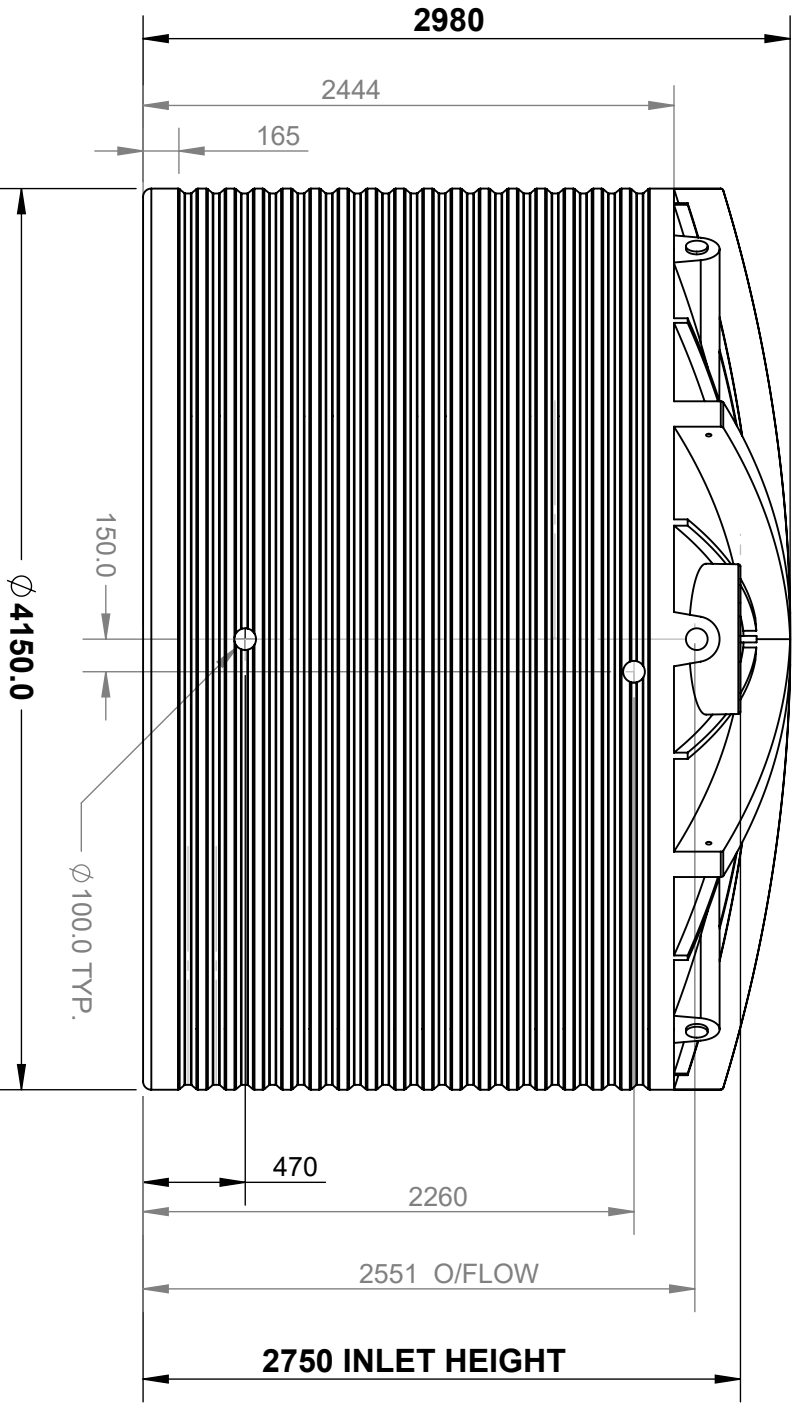
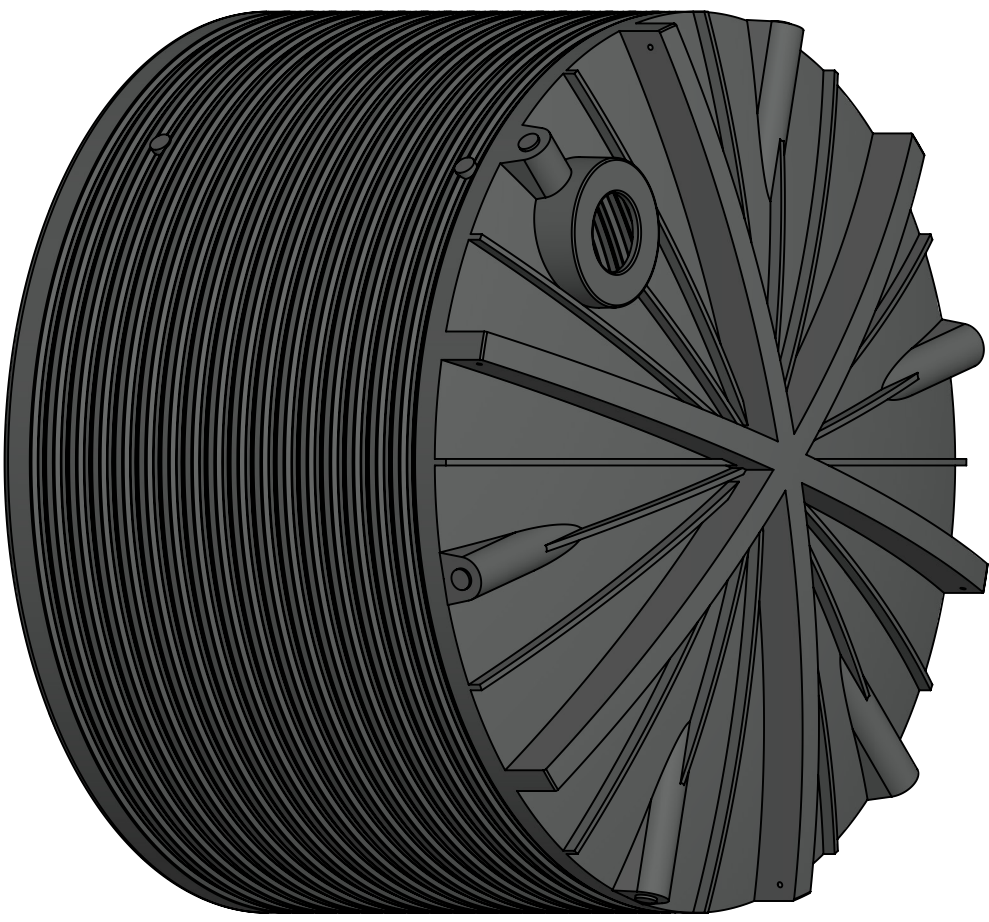
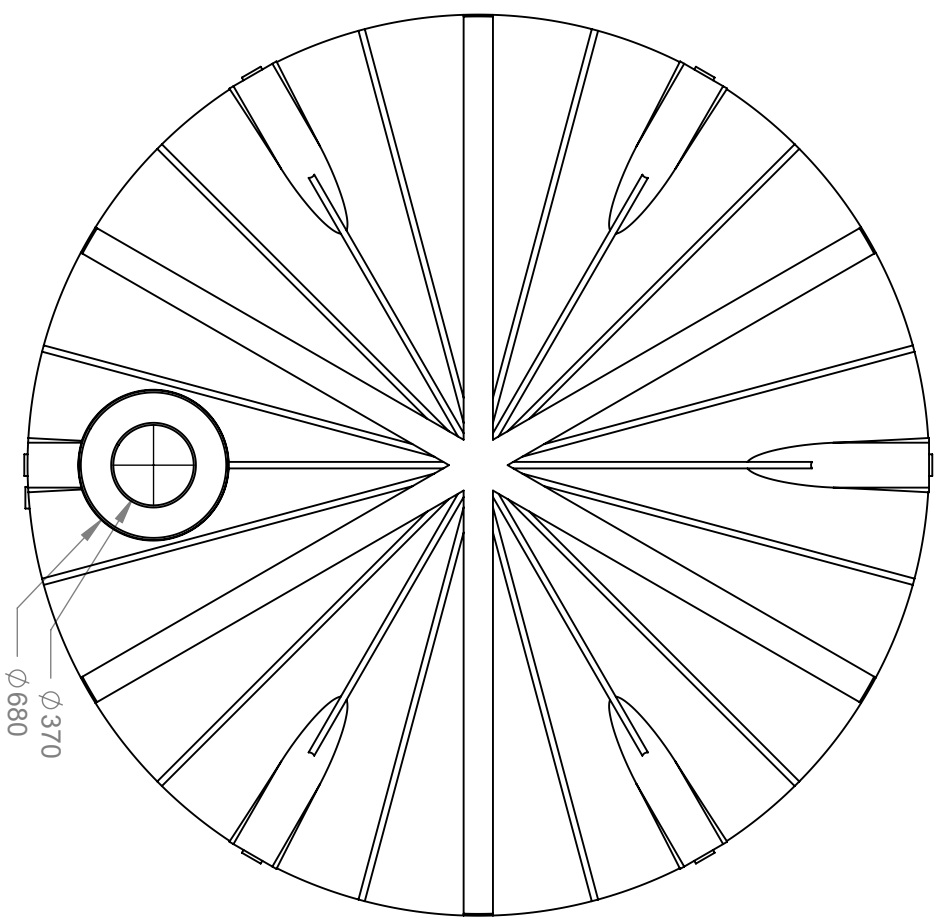

- DRAWING NOTES:
1. GENERAL TOLERANCES TO BE FOLLOWED IN TABLE, UNLESS OTHERWISE SPECIFIED
  2. SURROUNDED DIMENSIONS ARE CRITICAL
  3. ( ) SURROUNDED DIMENSIONS ARE FOR REFERENCE
  4. ANY UNMARKED OR MISSING DIMENSIONS USE STEP DATA OR NATIVE PARTS
  5. MATERIAL SUBSTITUTION ONLY WITH WRITTEN PERMISSION FROM CLARK TANKS
  6. ALL SHARP EDGES AND BURRS TO BE REMOVED

**31822L CT7000**

THIRD ANGLE PROJECTION NOT TO SCALE

DIMENSIONS IN MM		TOLERANCES UNLESS OTHERWISE SPECIFIED	
STANDARD		STANDARD	
0 PLACES DEC.	±1	0 PLACES DEC.	±1
1 PLACES DEC.	±0.3	1 PLACES DEC.	±0.3
2 PLACES DEC.	±0.10	2 PLACES DEC.	±0.10
3 PLACES DEC.	±0.05	3 PLACES DEC.	±0.05
ANGULAR	±1°	ANGULAR	±1°

REV	ECN / PE	STATUS / COMMENTS / NOTES	DRN	CHKD	DATE	PLACES DEC.	TOLERANCE
1							
2							
3							
4							
5							
6							
7							
8							
9							
10							

CRITICAL DIMENSIONS ENHANCED		AS	JG	26/03/2024	0 PLACES DEC.	±1
PRODUCTION RELEASE		AS	JG	19/03/2024	1 PLACES DEC.	±0.3
		AS	JG	19/03/2024	2 PLACES DEC.	±0.10
		AS	JG	19/03/2024	3 PLACES DEC.	±0.05
		AS	JG	19/03/2024	ANGULAR	±1°

**CLARK TANKS**

**Better Design. Better Build. Better Value.**

COPYRIGHT DETAILS:  
THIS DOCUMENT IS THE PROPERTY OF CLARK TANKS AND NOT FOR REPRODUCTION IN ANYWAY WITHOUT SPECIFIC WRITTEN PERMISSION FROM CLARK TANKS. DRAWINGS PREPARED BY WWW.ABIDCONSTRUCTANTS.COM

PART No. CT\_31822

DRAWING NAME CT\_31822

DRAWING No. CT 31822

SIZE A3 SHEET 1 OF 1